

XTOOL | M1 Ultra

Manual de referência rápida



Lista de itens - - - - - **01**

Conheça o seu xTool M1 Ultra - - - - - **02**

Preparação - - - - - **04**

Utilizar xTool M1 Ultra - - - - - **08**

Descrição do indicador - - - - - **16**

Lista de itens

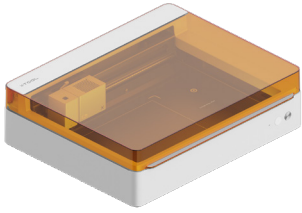

01 xTool M1 Ultra



02 Módulo laser



03 Módulo de evacuação de fumo



04 Cabo USB



05 Adaptador e cabo de alimentação



06 Lâmina de ponta fina



07 Caneta de ponta fina



08 Suporte de caneta

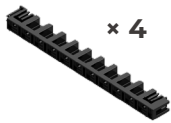

09 Suporte de prisma triangular

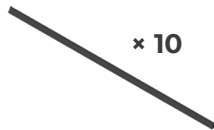

10 Prisma triangular

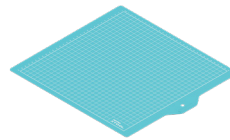

11 Esteira de corte (LightGrip)

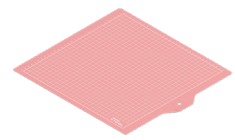

12 Esteira de corte (FabricGrip)



13 Filter



14 Chave



15 Lubrificante



16 Embalagem de material

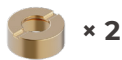

17 Montagem das lentes (peça sobresselente)



18 Peça rotativa da montagem das lentes



19 Chave de fenda



20 Carro multifuncional



21 Lâmina de corte



22 Parafuso borboleta para a placa de base (reserveonderdelen)



23 Manual de referência rápida



24 Instruções de segurança

Conheça o seu xTool M1 Ultra

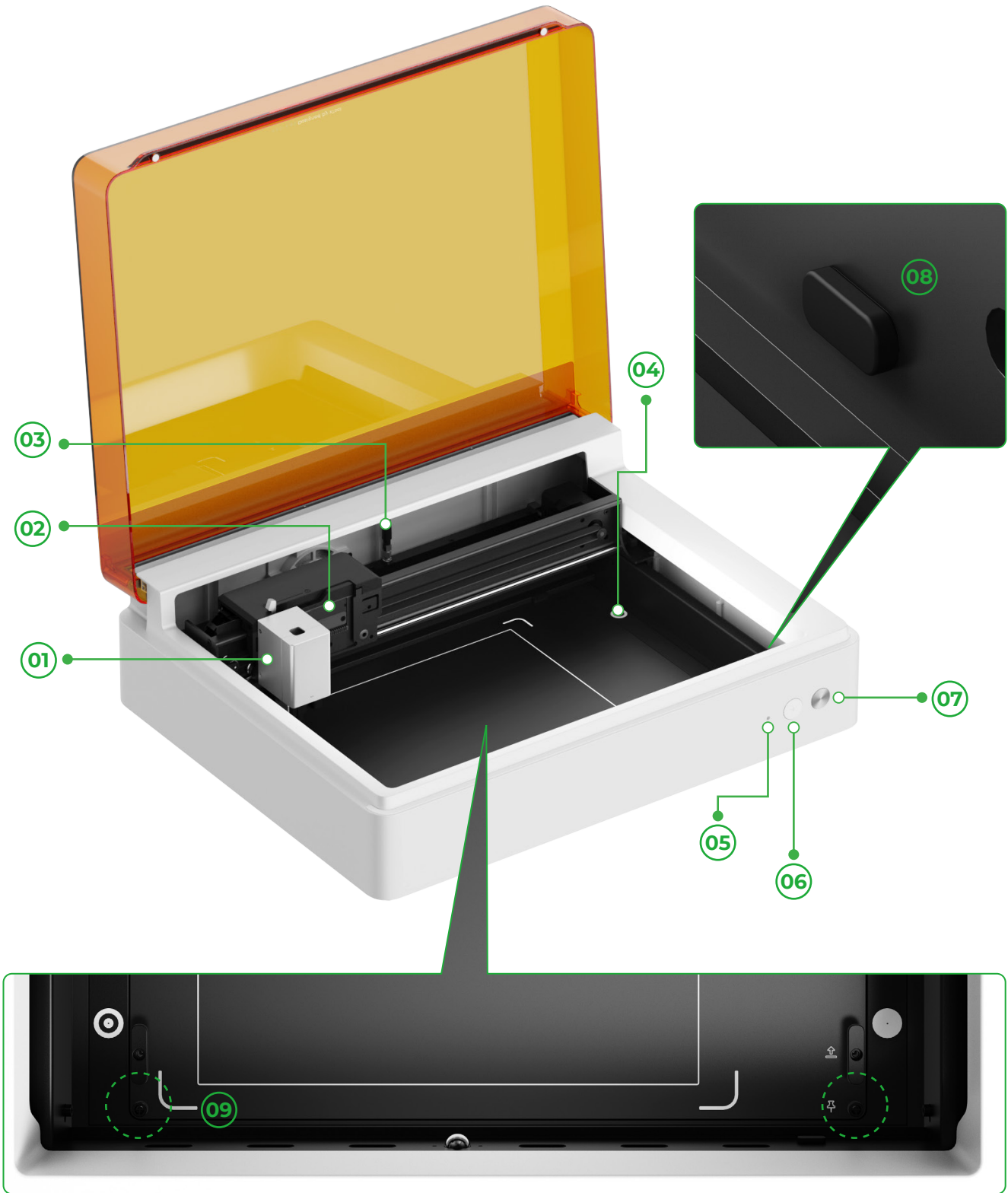

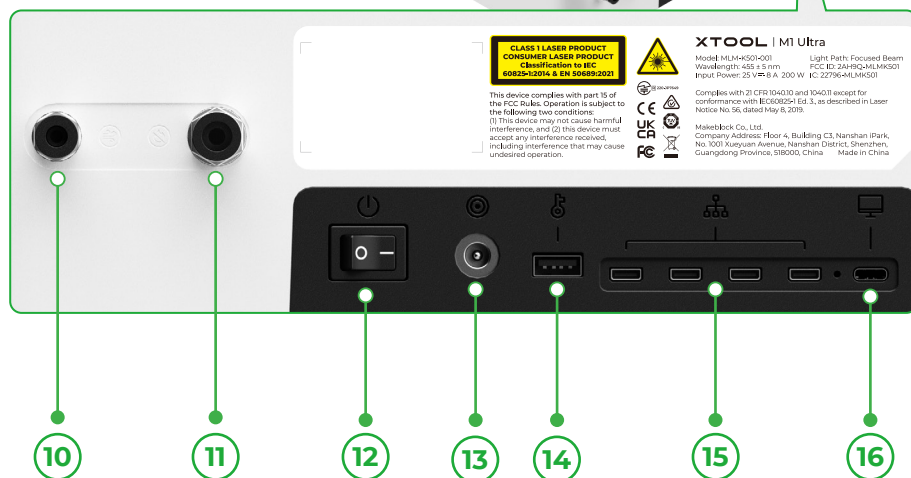
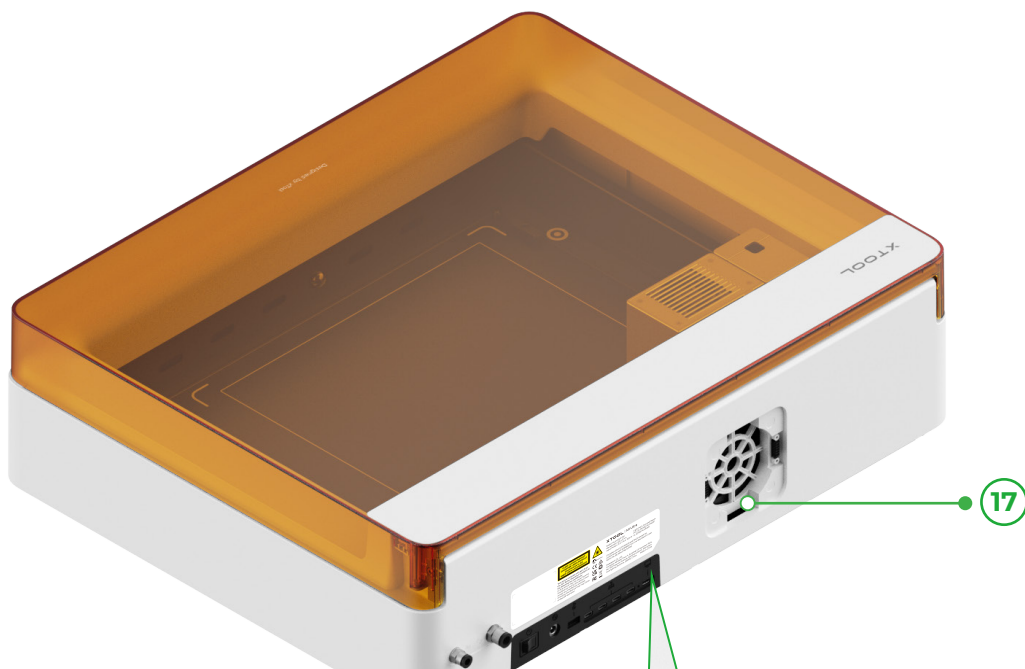

01 Carro básico

02 Suporte multi-funções

03 Antena Wi-Fi

04 Ponto visor da câmera

05 Indicador

06 Botão marcador de ponto

07 Botão Iniciar/Parar

08 Porta de acessório rotativo

09 Parafuso borboleta para a placa de base

10 Conexões de tubos para o kit de assistência de ar

11 Conexões de tubos para o kit de segurança contra incêndio

12 Interruptor de alimentação

13 Porta de alimentação

14 Porta para a chave

15 Porta de extensão × 4

16 Porta USB

17 Saída de Fumo

Preparação

- 1 Retirar os parafusos que fixam as calhas de guia do eixo x e do eixo y

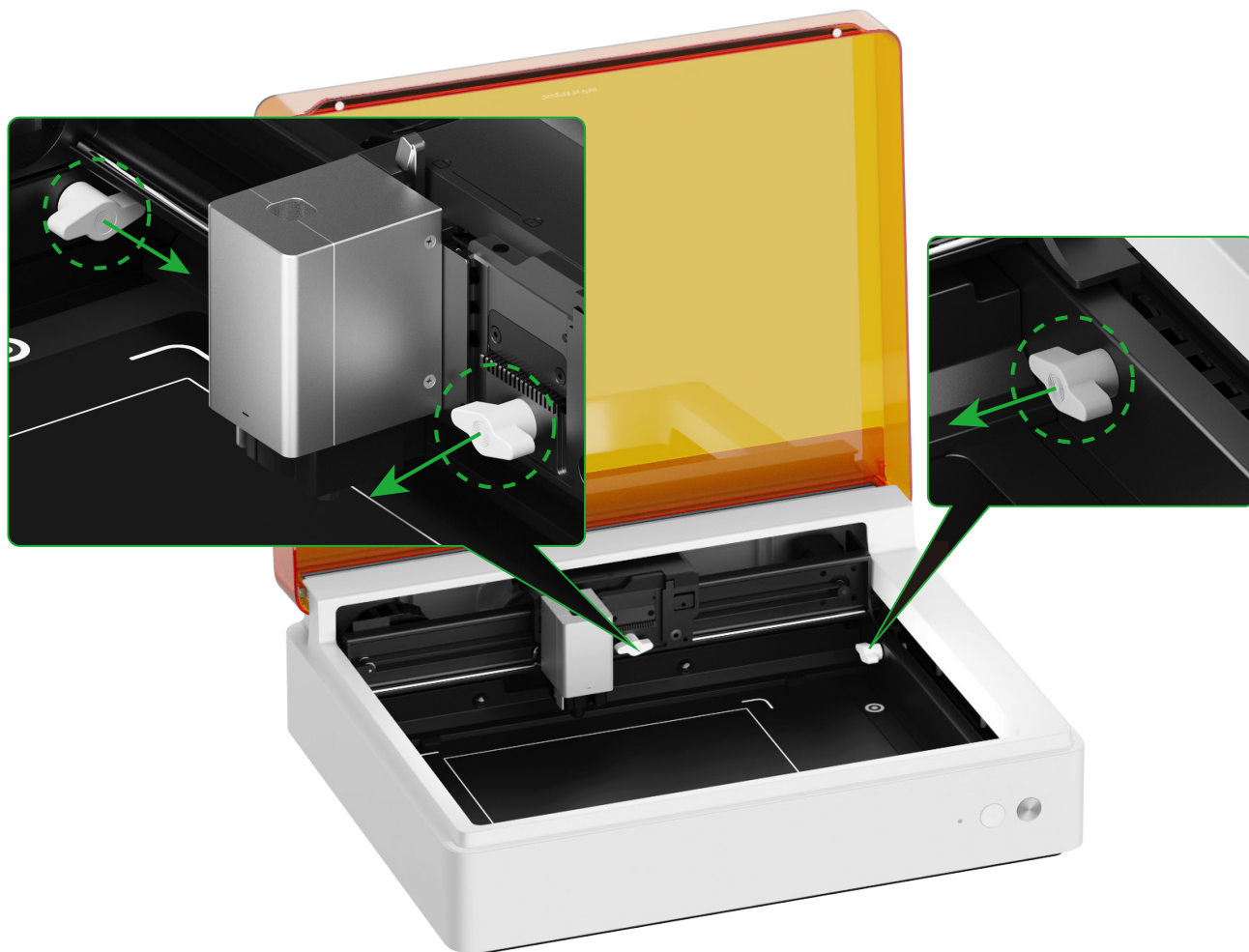

- 2 Instalar o módulo laser

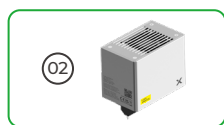

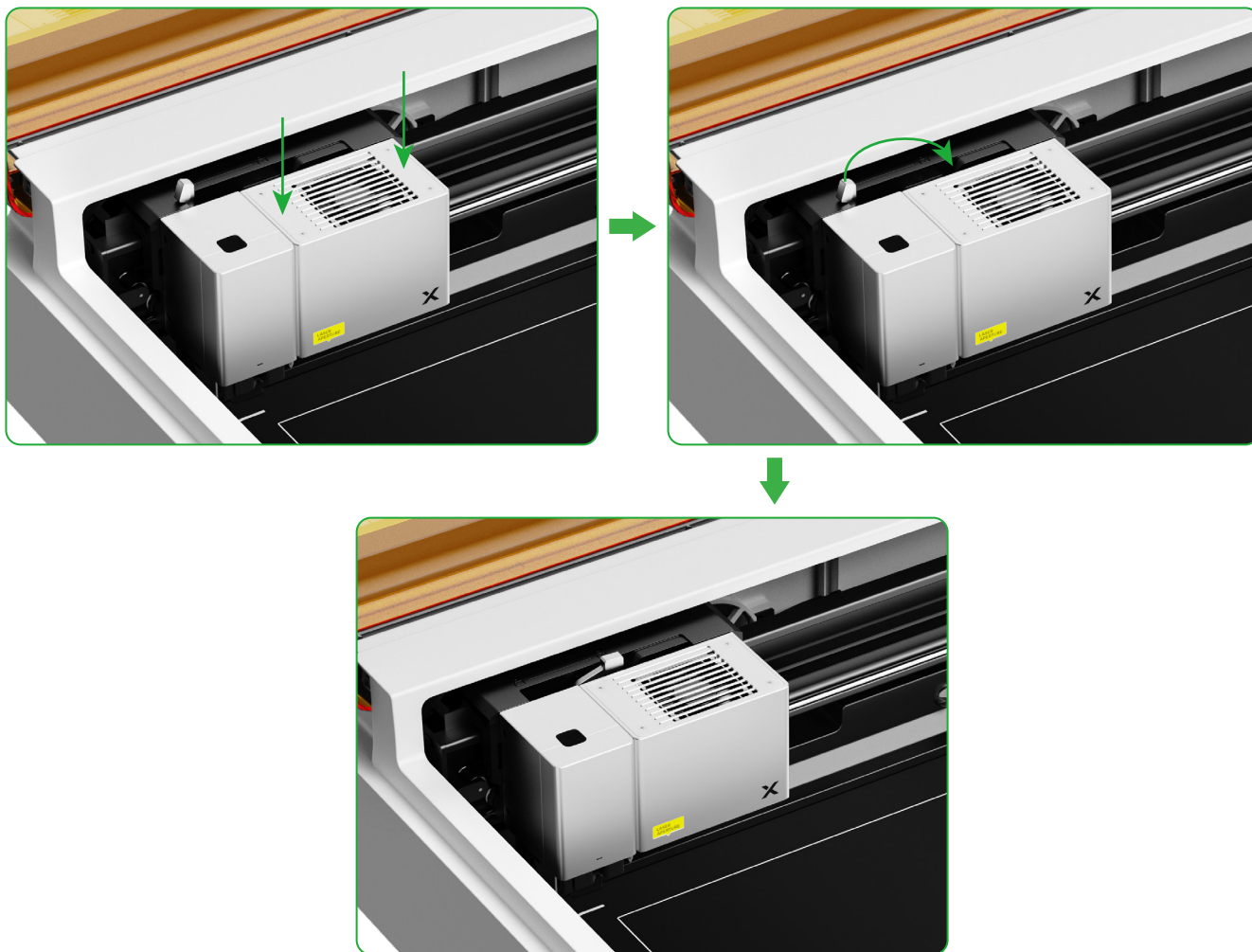

3 Instalar o módulo de extração de fumos

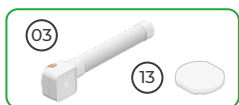

Não utilizar o módulo de evacuação de fumo sem o filtro. Ou ele poderá absorver fumo e poeira e ficar avariado.

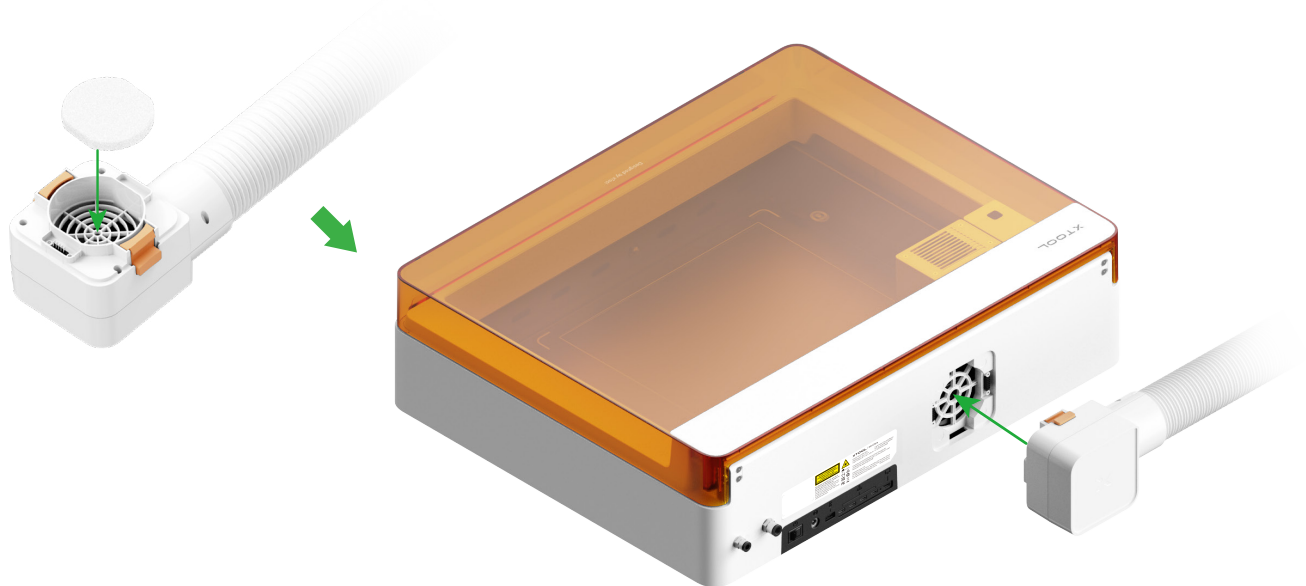

4 Insira a chave

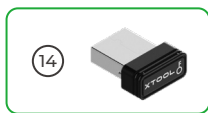

- Insira a chave para desbloquear o acesso ao processamento e às funções relacionadas.
- Poderá remover a chave para bloquear o acesso ao processamento e às funções relacionadas.

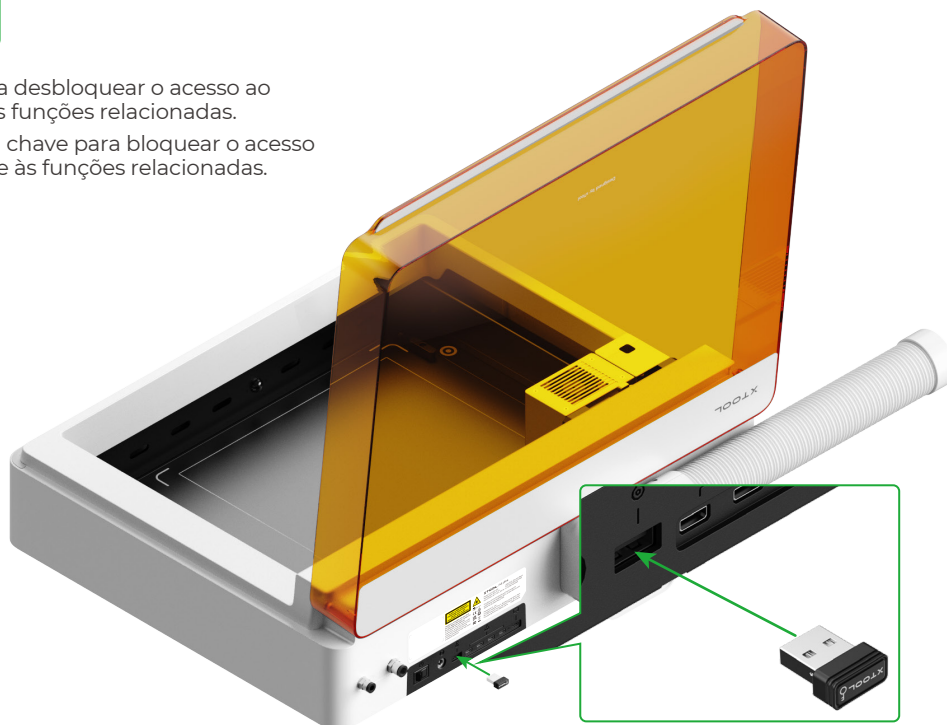

5 Ligue a uma fonte de alimentação.

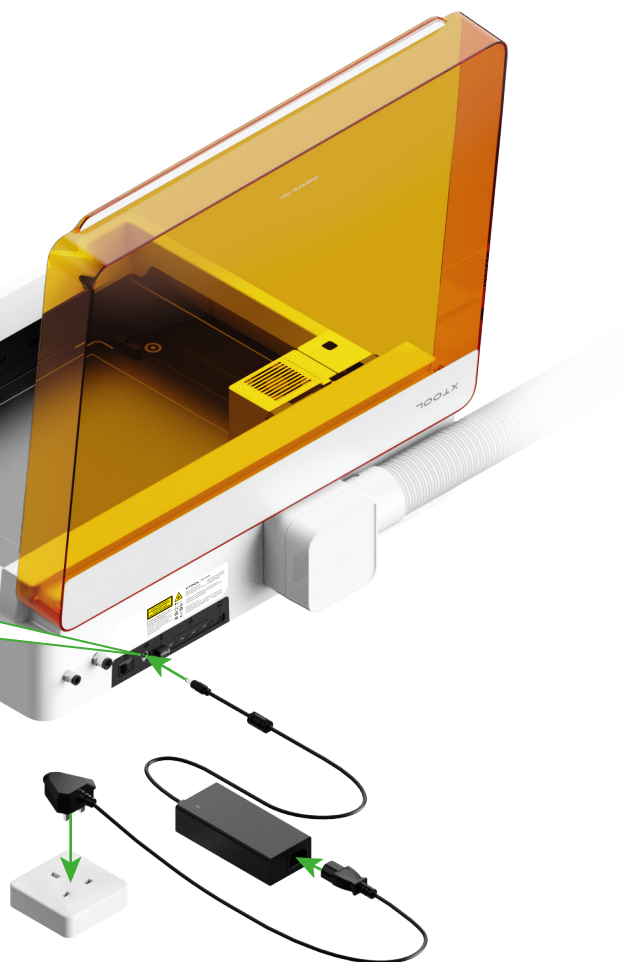
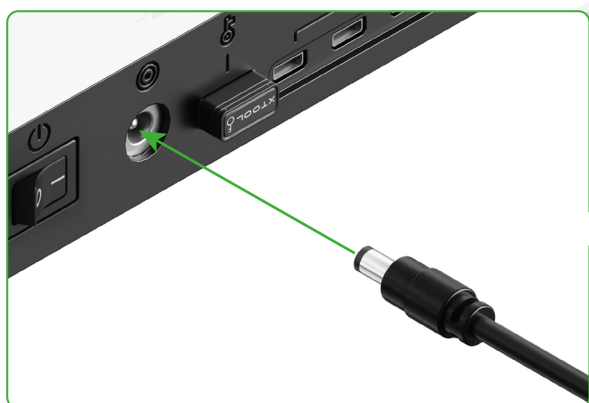
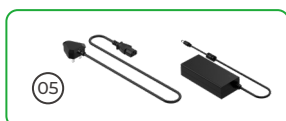

6 Descarregar e instalar o xTool Creative Space (XCS)

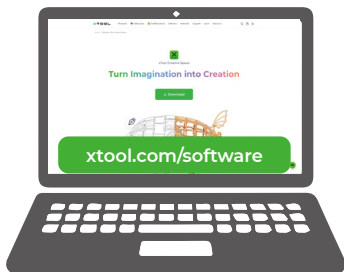

Visite o site xtool.com/software para transferir e instalar o xTool Creative Space (XCS).

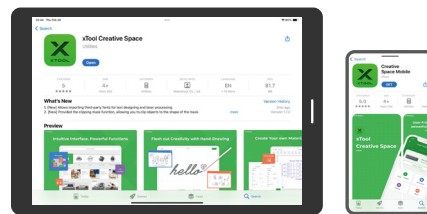

Procure **xTool Creative Space** em uma loja de aplicativos ou digitalize o código QR a seguir para baixar o aplicativo.



7 Ligar o xTool M1 Ultra a um computador

- Ligue o xTool M1 Ultra, ligue-o a um dispositivo e, em seguida, ligue-o ao XCS.



- Para obter detalhes sobre como usar o software para operar o xTool M1 Ultra para processamento de materiais, digitalize o código QR ou visite support.xtool.com/product/35.



Utilizar xTool M1 Ultra

Para corte a laser

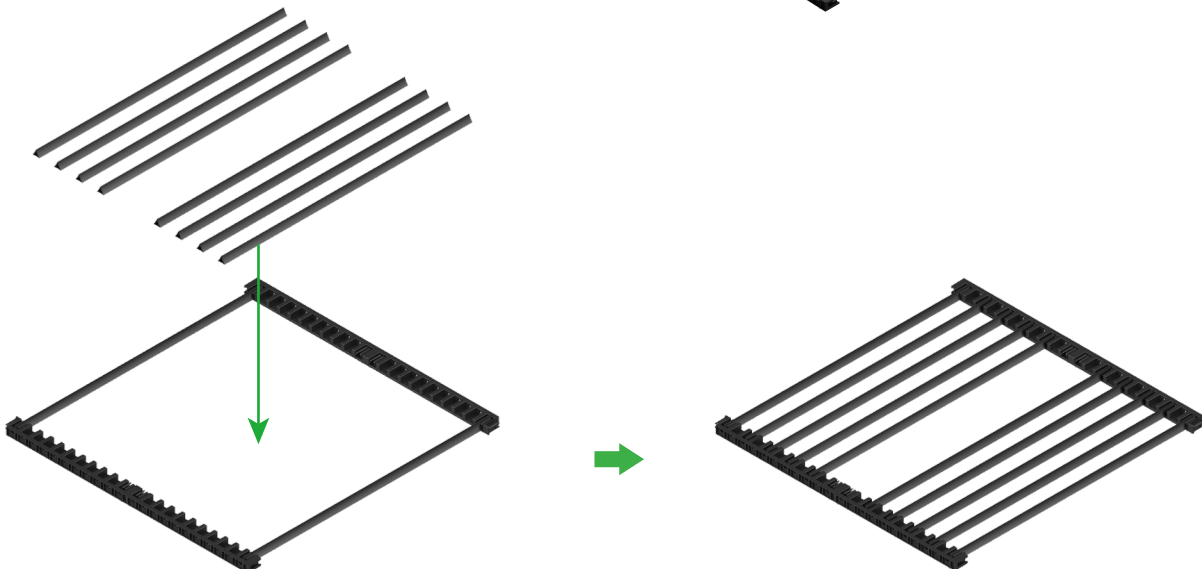
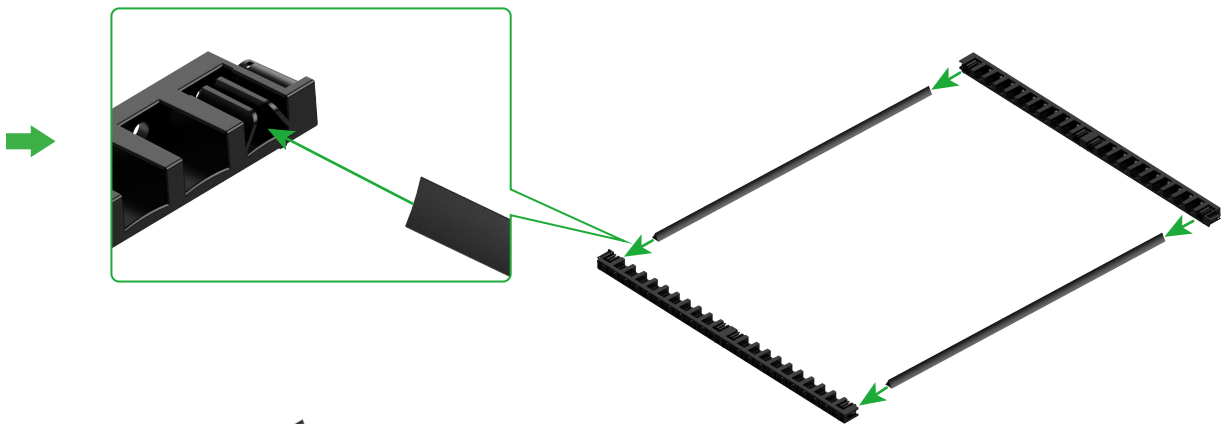
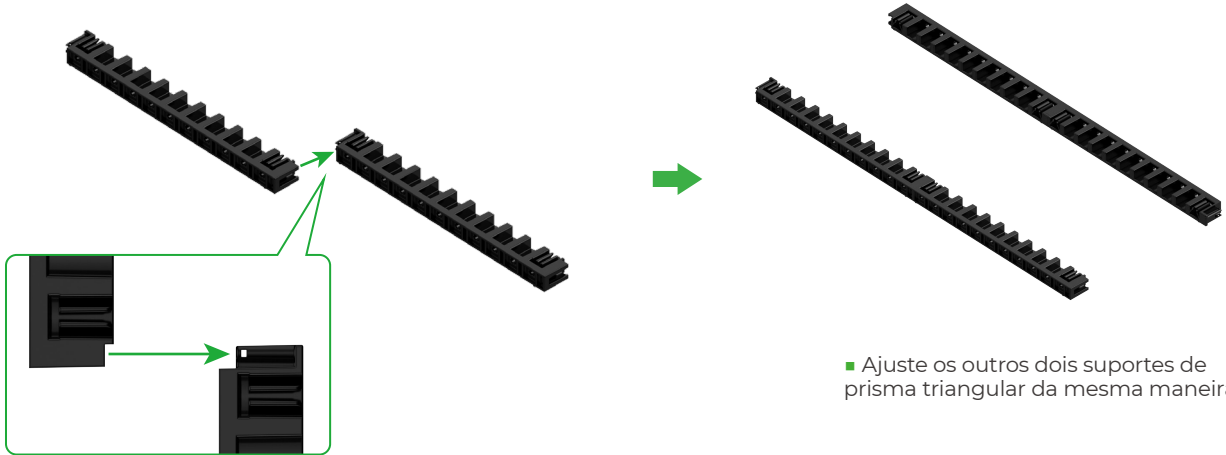
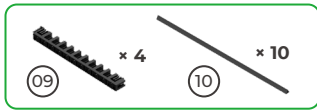

■ Determinar o número dos prismas triangulares baseando-se no material a ser processado.

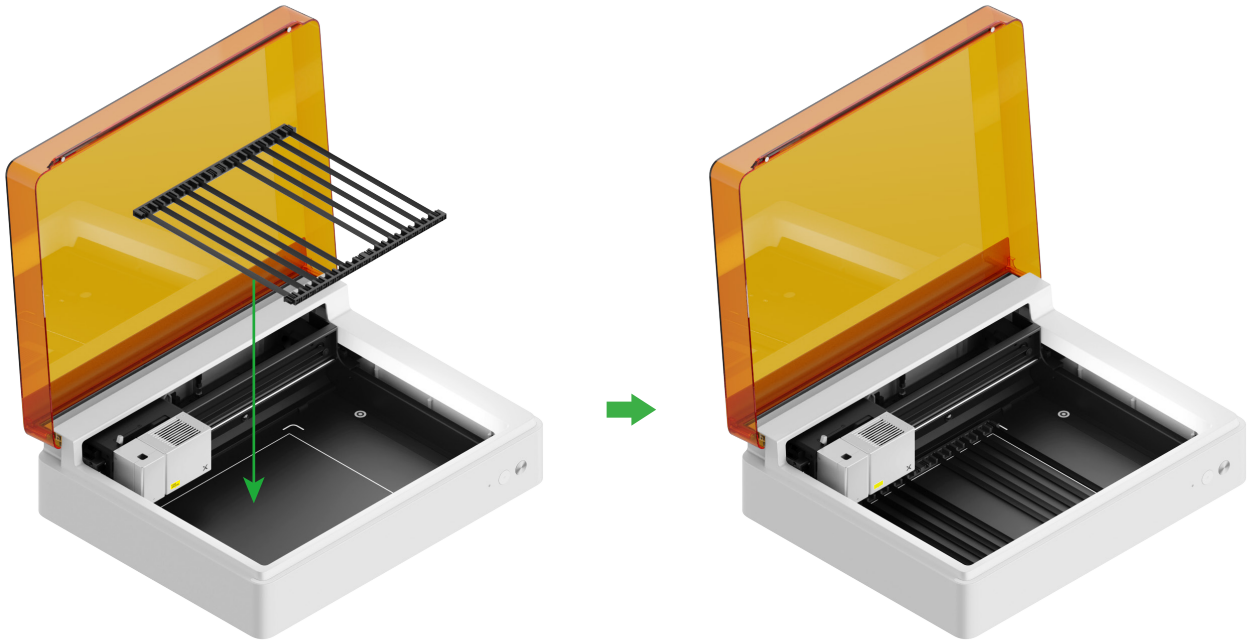

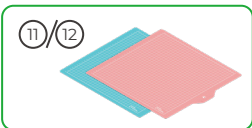

Para corte de lâmina ou combinação de processamento a laser e corte de lâmina

(1) Colocar o tapete de corte na placa de base



Nota: Para materiais de papel, tais como papelão e papel kraft, use a esteira de corte LightGrip; e para materiais tecidos como pano, use a esteira de corte FabricGrip. Não use nenhuma esteira de corte ao cortar um material com raios laser.

Esteira de corte		
Cor	Azul	Cor-de-rosa
Aplicável a	Materiais leves	Tecidos
Material	Papelão, Papel para embalagens, Papel para impressão, Papel Kraft, Papel pérola	Tecido

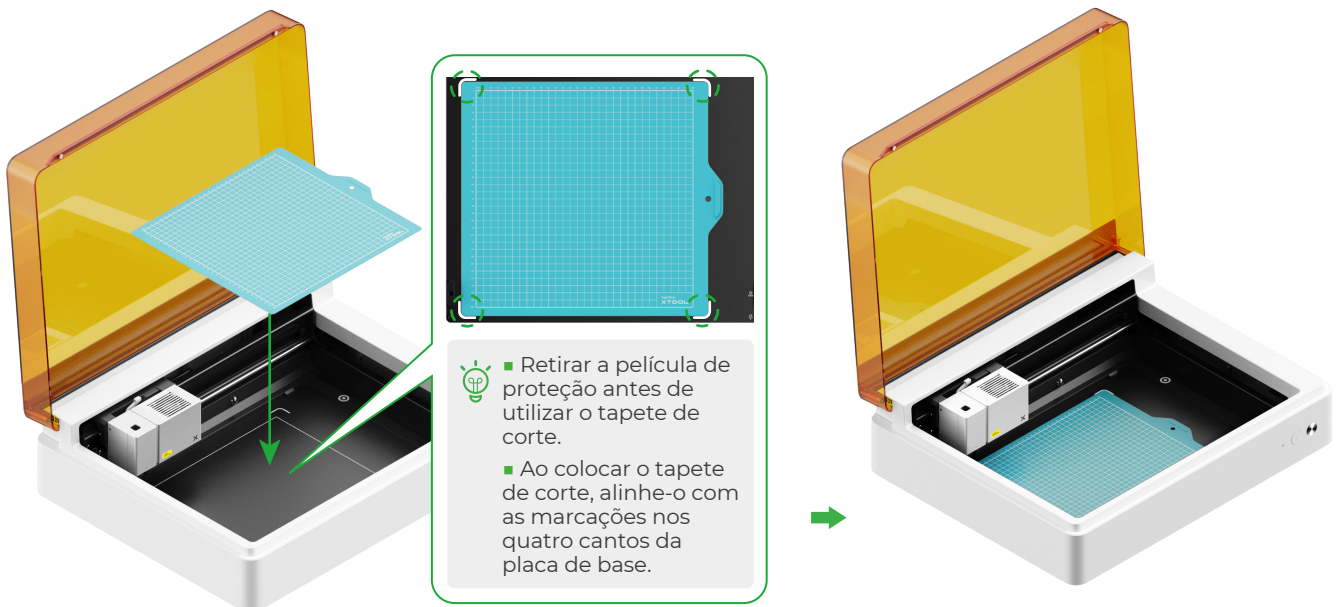

(2) Instalar a lâmina de ponta fina no carro básico

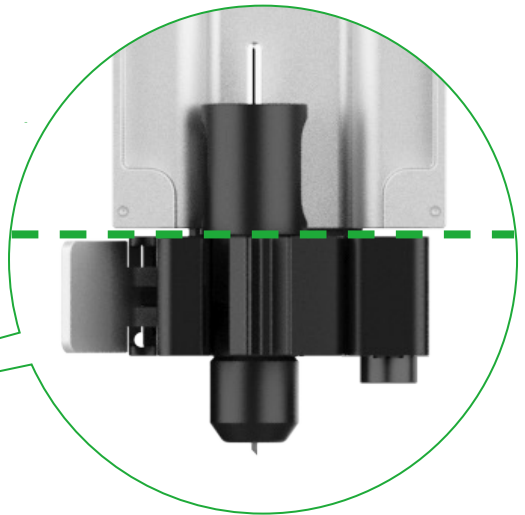
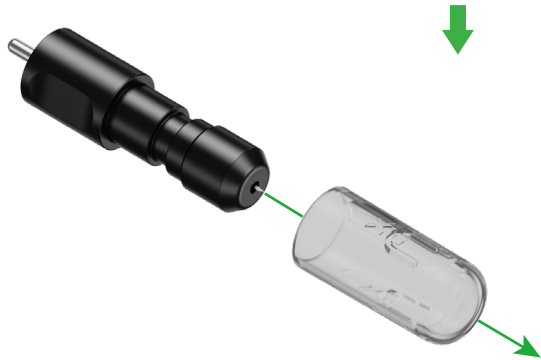
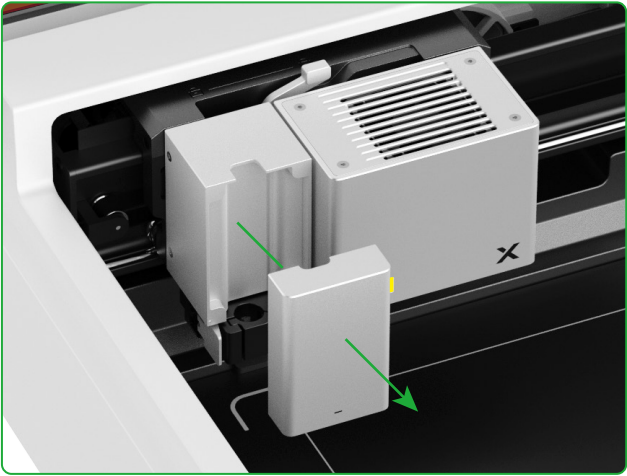

Cuidado!
Lâmina afiada

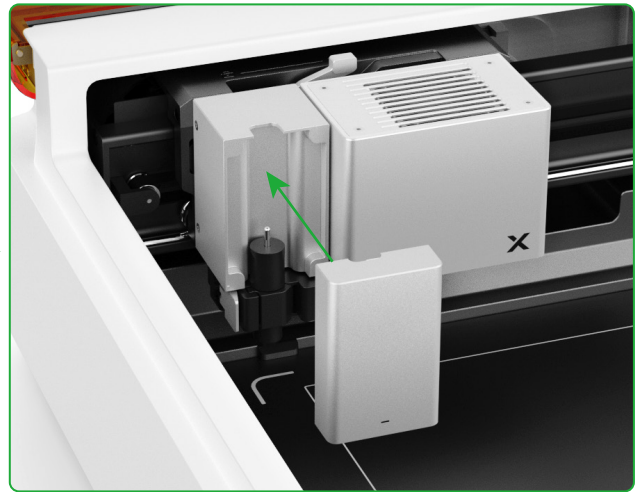
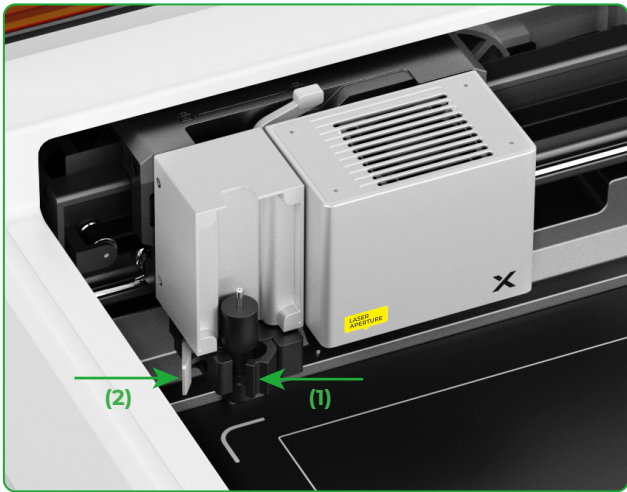

Para desenho a caneta

(1) Instalar a caneta de ponta fina no suporte da caneta

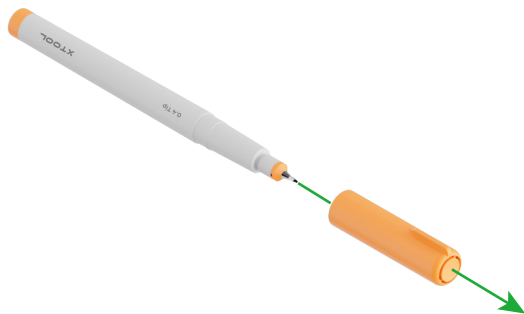

(2) Instalar a caneta de ponta fina no carro multifunções

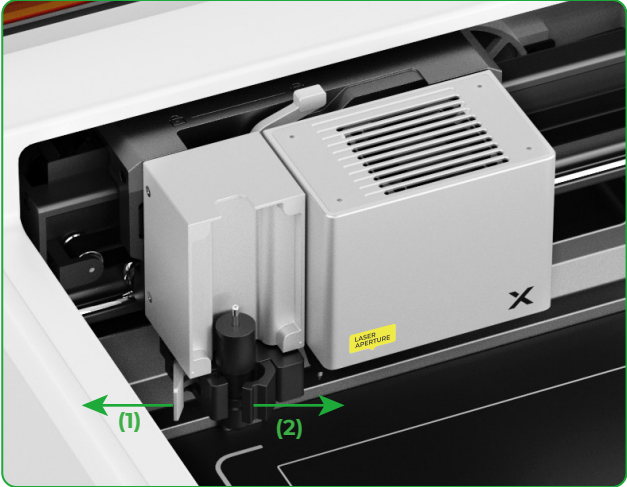

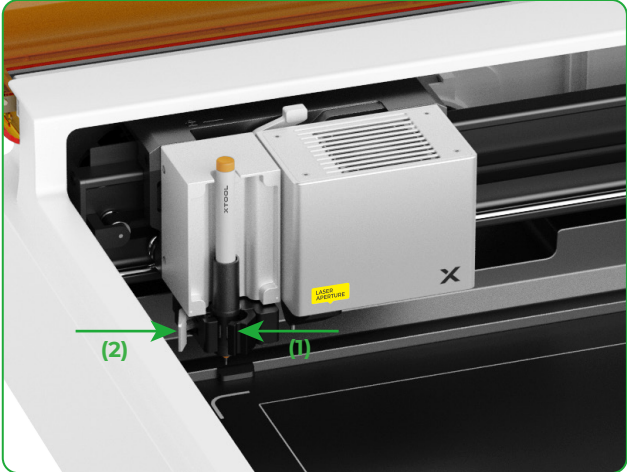
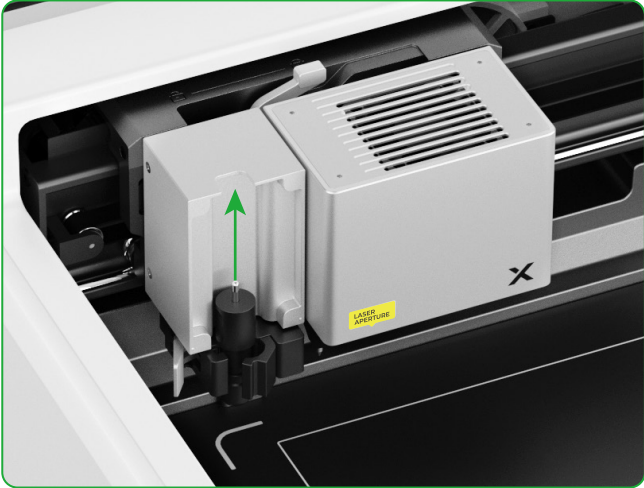

Cuidado!
Lâmina afiada

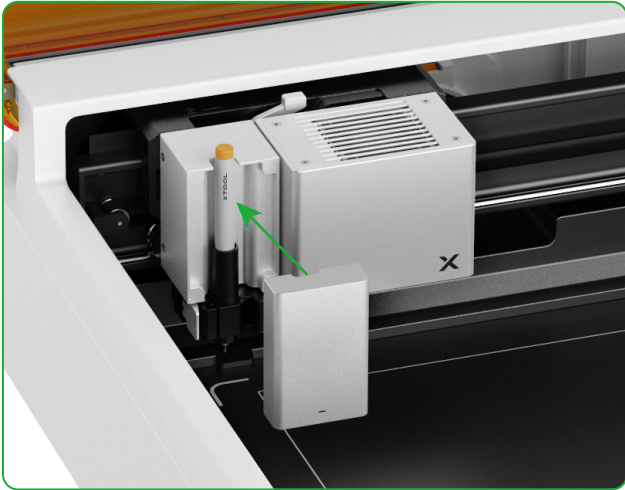

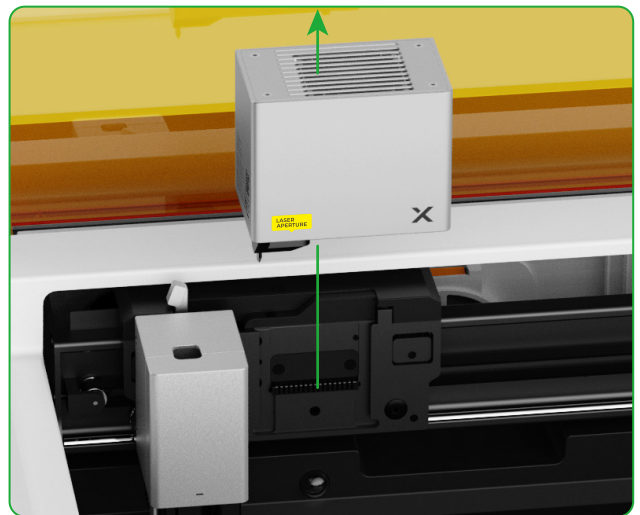
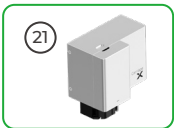

Para mais funções

(1)



(2) Instalar o acessório no carro multifunções

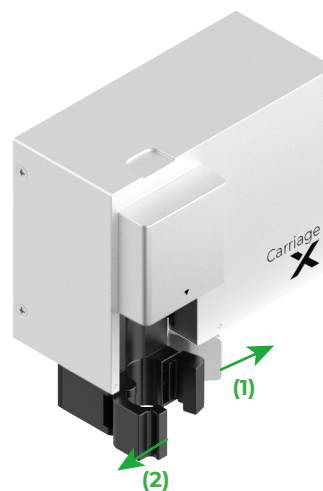
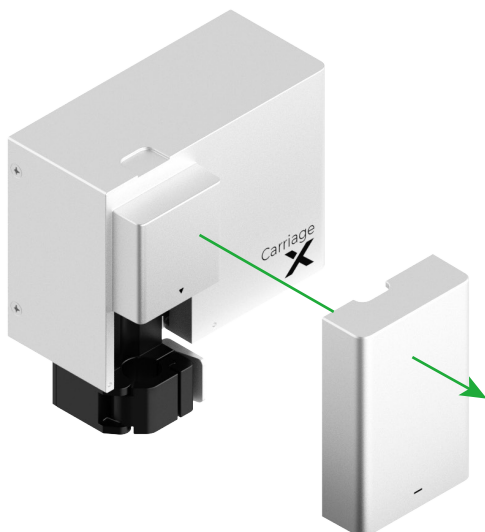



Selecionar os acessórios de acordo com as necessidades do processamento.

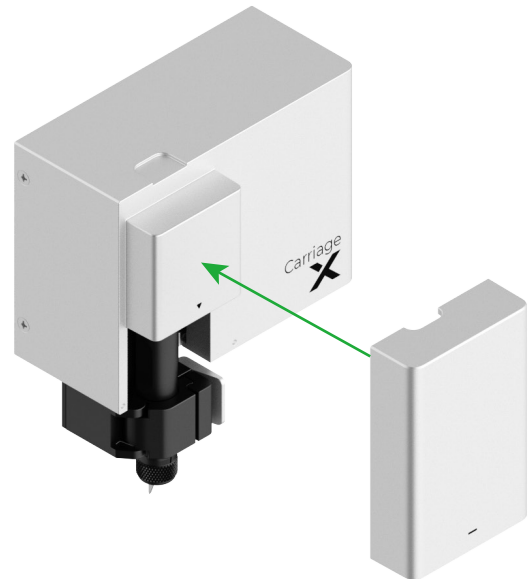
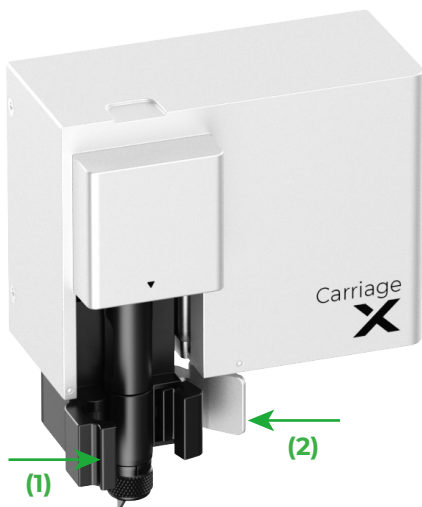
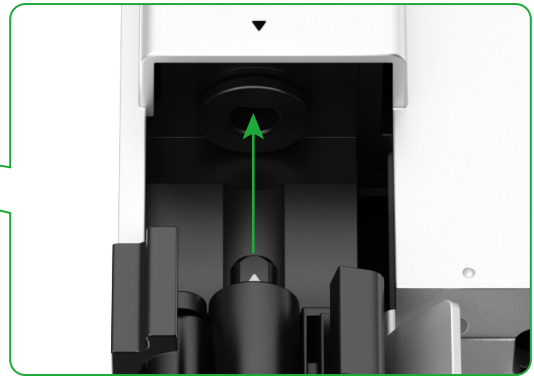
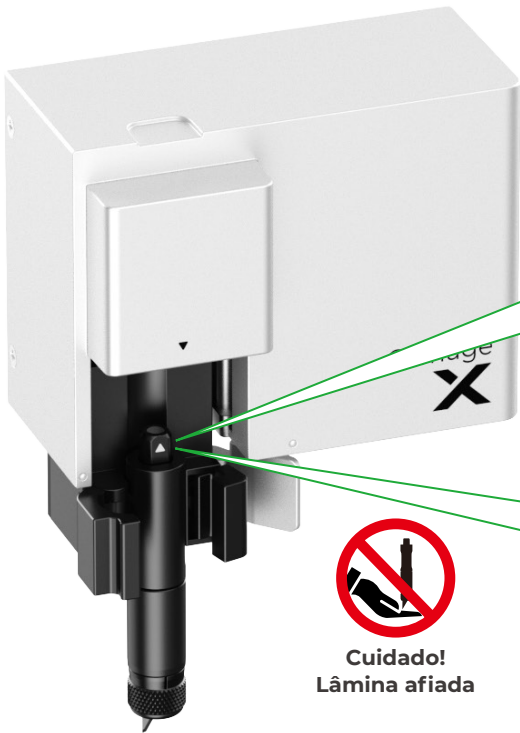
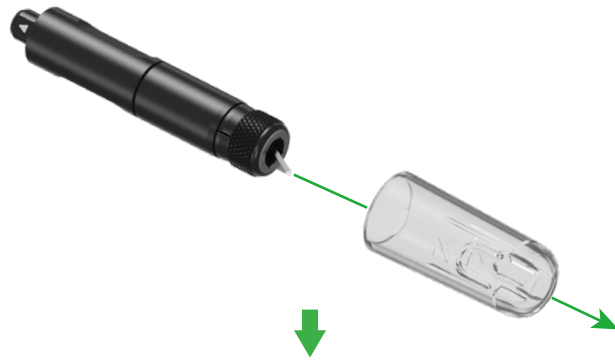

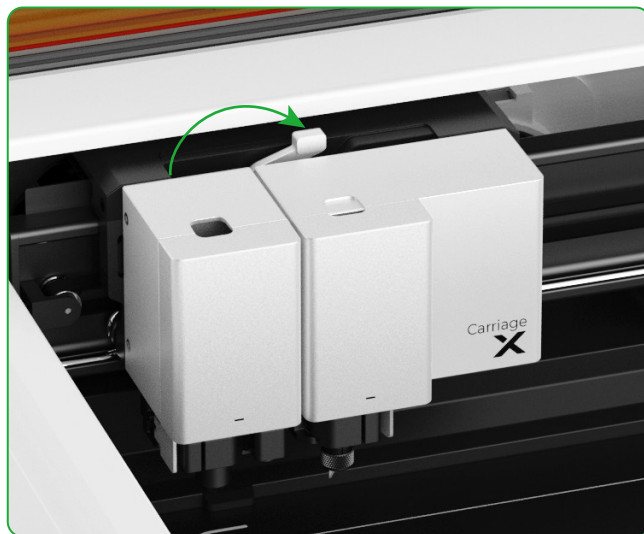
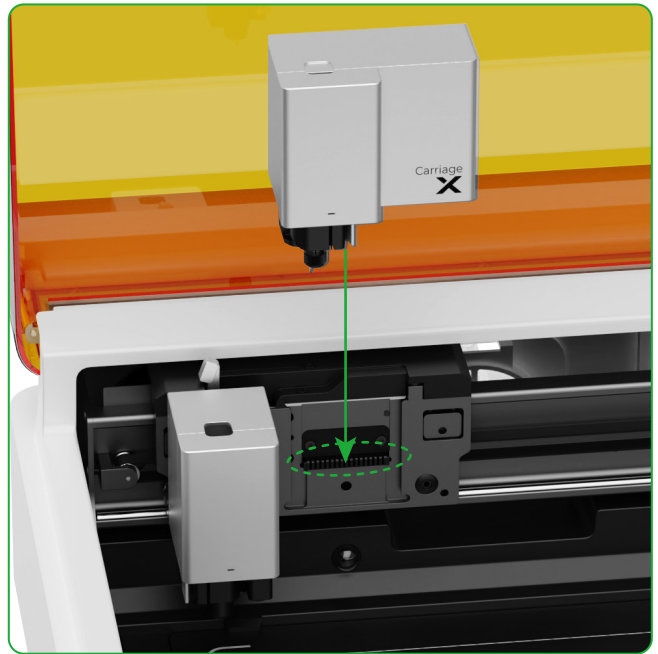

Descrição do indicador

Estado do indicador	Estado do sinalizador sonoro	Estado da máquina
 Branco sólido	/	Em espera, não conectado ao XCS (no modo AP)
 Azul claro sólido	/	Em espera, não conectado ao XCS (no modo STA)
 Lilás sólido	Soar uma vez	Em espera, conectado ao XCS
 Branco respirando	/	Dormindo, não conectado ao XCS
 Lilás respirando	/	Dormindo, conectado ao XCS
 Lilás intermitente lento	/	Atualização de Firmware
 Verde sólido	/	Marcação de área de processamento no XCS / Enquadramento / Processamento
 Azul intermitente lento	Soar uma vez	Pronto para enquadramento / Pronto para processar
 Azul sólido	/	Tarefa pausada
 Amarelo intermitente	Soar uma vez	A tampa está aberta ou não está completamente fechada durante o funcionamento.
 Amarelo intermitente	Manter o som	Chama detetada (chama pequena) / Sacudir o dispositivo
 Vermelho intermitente	Manter o som	Chama detetada (chama grande)
 Amarelo intermitente	Soar três vezes	Ocorreram exceções
 Vermelho intermitente	Soar três vezes	Ocorreram exceções importantes

XTOOL